

 **MACDONALD**  
INSTRUMENTS

# 2 BAND FM SCANNING MONITOR

UHF BAND 450-470 MHz

VHF BAND 148-174 MHz



**INSTRUCTION MANUAL**

**MODEL NO. CE-100**

**CODE NO. 6-32-90**

WARNING: TO PREVENT FIRE OR SHOCK HAZARD, DO NOT EXPOSE THIS  
APPLIANCE TO RAIN OR MOISTURE.

## GENERAL DESCRIPTION

This UHF—VHF dual programmable scanner receives sixteen (16) fixed crystal frequency in two (2) bands, eight (8) in the VHF band 148—174 MHz and eight (8) in the UHF band 450—470 MHz. This scanner has stability and some unique features which you will not find in many other scanners now being sold.

- 1) Very compact and easy installation for mobile or base station operation.
- 2) This scanner will operate from 12 volts DC or 117 volts AC Both cords are included.
- 3) Scanning monitor can be operated manually or automatically.
- 4) Two antennas. One for UHF one for VHF are provided for best results during base station operation.
- 5) Squelch control for noise reduction.
- 6) Manual operation select button.
- 7) Auto operation select button.
- 8) LED band indicator lights.
- 9) Built in speaker and jack for external speaker.
- 10) 8 or 16 channel select button.
- 11) This unit has 5 IC (integrated circuits), 34 transistors, 36 diodes and 2 LED.
- 12) This scanner is designed for negative ground operation only.

### ● CAUTION:

The fuse of the DC cord set is of 1.0 Ampere.

Electrical values are subject to change without notice.

### ● ACCESSORY:

UHF Antenna Set .....	1
VHF Antenna Set .....	1
AC Cord Set .....	1
DC Cord Set .....	1
Mounting Bracket .....	1
Antenna Plug .....	2
Accessory Screws .....	4
Instruction Book .....	1
Fuse 1.0 Ampere .....	1
Washers .....	8

### ANTENNA PLUG & CABLE ASSEMBLY

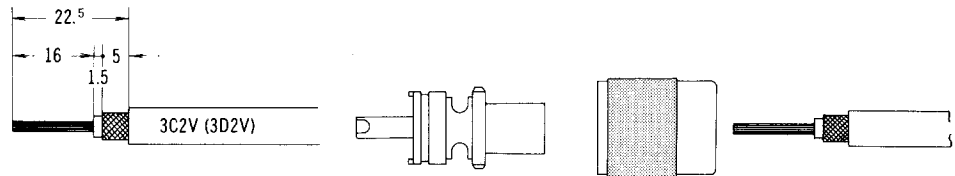

## CRYSTAL INSTALLATION

Suitable crystals must be installed before operation.

- 1) Remove 2 screws located on the lower side of unit and remove cover.

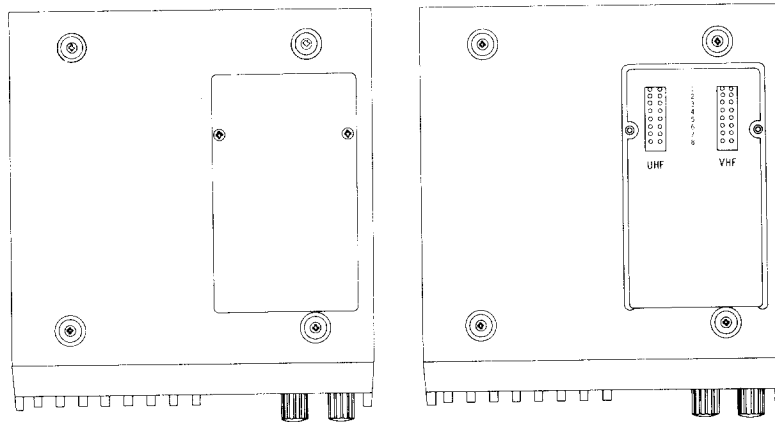

- 2) Install crystals in the sockets according to the channel numbers. Be careful not to bend crystal pins.
- 3) The crystals must be carefully selected in accordance with the basic receiving frequency.

$$\text{VHF-Band Crystal frequency} = \frac{\text{Channel frequency} - 10.7 \text{ MHz}}{3}$$

$$\text{UHF-Band Crystal frequency} = \frac{\text{Channel frequency} - 10.7 \text{ MHz}}{9}$$

#### 4) CRYSTAL SPECIFICATIONS:

- |                      |                    |                         |                           |
|----------------------|--------------------|-------------------------|---------------------------|
| 1. Holder type       | : HC-25 U          | 6. Shunt Capacitance    | : Less than 6 pF          |
| 2. Resonance         | : Series           | 7. Frequency Tolerance: | : 0.002% (-20°C to +50°C) |
| 3. Load Capacitance: | 32 pF              |                         |                           |
| 4. Drive Level       | : 2.0 mW           |                         |                           |
| 5. Resistance        | : Less than 35 ohm |                         |                           |

## CONTROLS AND OPERATION

### **ON-OFF VOLUME CONTROL:**

The volume control varies the sound output of the loudspeaker. It also functions as "on—off" switch. Clockwise rotation increases the volume level.

### **SQUELCH CONTROL:**

The squelch control is designed to reduce excessive noise (such as high line interference, ignition noise, etc.). This control must be set when only noise (no signal) is heard. Turn the control fully counter clockwise and increase the volume until noise or a signal is heard. When only noise is present, turn the squelch control clockwise until the noise is blanked out.

### **MANUAL/AUTO SWITCH (Function Switch):**

#### **MANUAL Position:**

You can select the channels manually by pushing the "SELECT" button.

#### **AUTO Position:**

After incoming signal has stopped, it holds the channel for 2 seconds before scanning to the next channel.

### **UHF-OFF-VHF SWITCH:**

For VHF scanning, set the switch at "VHF" position (upper side), and for UHF scanning, set the switch at "UHF" position (lower side). When the switch is in "OFF" position, that channel does not receive any incoming signal. For example, if you do not need to scan channel 1, 2 and 3, put the channel 1, 2 and 3 switches at "OFF" position. Then the unit scans from channel 4 through channel 8.

### **CHANNEL INDICATOR LIGHTS:**

The channel indicator lights show which channel is scanning. When scanning, the light of that channel is illuminated.

### **AC POWER SOCKET:**

A socket is provided on the back of the unit for connection to external source of 117 V 60Hz AC.

### **DC POWER SOCKET:**

A socket is provided on the back of the unit for connection to external source of 12 V DC, Red (+) and Black (—) wire.

### **EXT. SPEAKER JACK:**

A jack is provided at the back of the unit for connection to external speaker.

### **ANTENNA CONNECTOR:**

Two (2) antenna connectors are provided at the back of the unit for UHF and VHF. This antenna connector is usable for external antenna also.

### **BAND INDICATOR:**

2 LED's are provided on the front panel for indication of UHF and VHF.

### **16/8+8 CHANNEL SWITCH:**

When button is pushed in at 8+8 channel, the unit will scan through 8 channels where the switches (UHF—OFF—VHF) are positioned.

When button is released for 16 channel, the unit scans all 16 channels regardless of where switches (UHF—OFF—VHF) are positioned. But, if the switch (UHF—OFF—VHF) is at "OFF" position, that channel will not be scanned.

**FRONT VIEW**

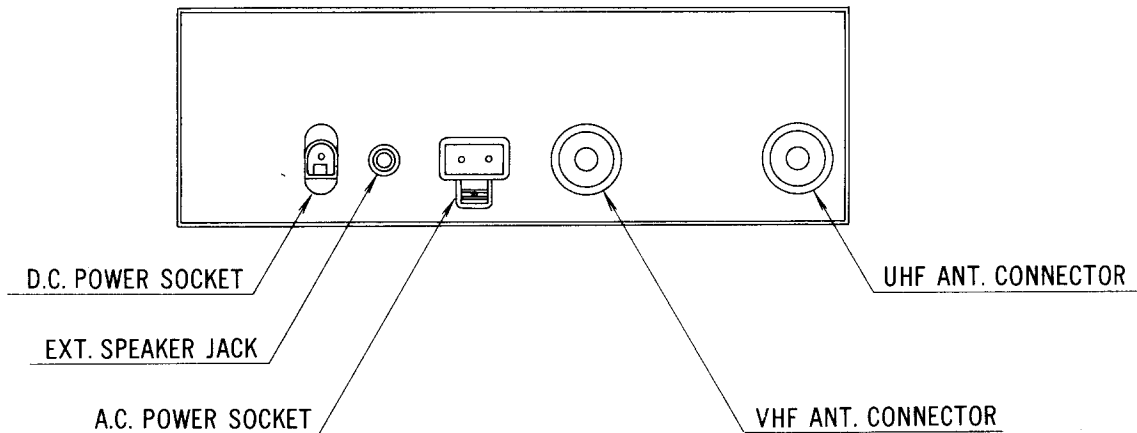
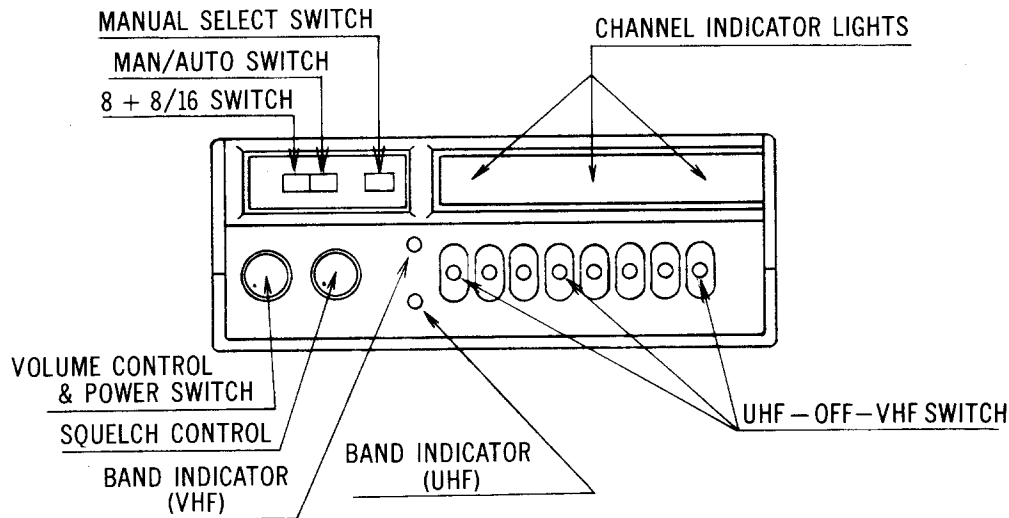

## INSTALLATION

### A) MOBILE USE

- 1) A location in the car or truck should be chosen carefully for convenience of operation and non-interference with normal driving function. Mounting should be under the dash or instrument panel. A secure installation should be made.
- 2) Install the mounting bracket under the dash or instrument panel. Then secure the scanner unit to the mounting bracket as shown.

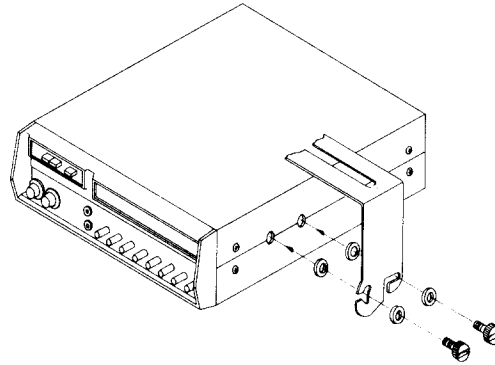

- 3) To use the car antenna, insert the service accessory plug into the antenna jack on the back of the set. (Make sure to extend the car antenna about 20 inches to match 150 Mhz band, and about 65 inches to match 450 Mhz band.)
- 4) Plug in DC cord to the set.  
Connect Red (Plus) cord with plus (+) pole of the car battery ( 12 V ) and Black (Minus) cord with Minus (-) pole. Otherwise, the set will be damaged.

This unit is designed for negative ground only. Be sure to check the connection for polarity, to avoid damage by wrong connection.

### B) BASE STATION USE

To use the scanner as a fixed base station, follow the instructions below.

- 1) Connect the antennas supplied to the rear pannel of the set. Make sure the plug is securely tightened to the jack.
- 2) The antenna which has one section only is for UHF reception. The one with 2 sections is for VHF operation. Be sure to extend the rod by screwing the two parts together.
- 3) Connect the AC power (117V) cord to your set first, then plug it into the power outlet. Set the antenna in position for most efficient reception. When the set is used in the areas of low signal strength, use a Ground Plane Antenna or ask your dealer for the correct type of antenna to use.

## SPECIFICATIONS

1. Frequency Range : UHF Band ..... 450 — 470 MHz (20 MHz Coverage)  
VHF High Band ..... 148 — 174 MHz (10 MHz Coverage)

**CAUTION:** On VHF frequency range 148 — 174 MHz, CE - 100 is pre-adjusted with 10 MHz coverage of center frequency 155 MHz Plus-minus 5 MHz (150—160 MHz). If range other than the pre-adjusted frequency above is desired purchase crystal from your dealer in accordance with crystal specification and have it adjusted by your dealer or qualified engineer.

2. Sensitivity : UHF Band ..... at 20 dB NQ 0.7  $\mu$ V  
VHF High Band ..... at 20 dB NQ 0.5  $\mu$ V
3. Selectivity : 6 dB  $\pm$  7.5 KHz  
50 dB  $\pm$  12 KHz
4. Frequency Deviation:  $\pm$  5 KHz
5. I. F. Frequency : 1st I. F. 10.7 MHz  
2nd I. F. 455 MHz
6. A.F. Output Power : 1.5 Watts at 10% distortion
7. Scanning Speed : 13 ch/sec.
8. Delay time : 2 sec.
9. Antenna : Two (2) rod antenna, each for UHF and VHF (External antenna 50 ohms)
10. Semiconductor : IC 5, Transistor 34, Diode 36, LED 2
11. Power Supply : DC 12V, AC 117 V
12. Power Consumption: 8 Watts.
13. Center Frequency at each band tuned:  
UHF Band ..... 460 MHz  
VHF High Band ..... 155 MHz
14. Band Width : UHF Band ..... 20 MHz ( $\pm$  10 MHz)  
VHF High Band ..... 10 MHz ( $\pm$  5 MHz)

# BLOCK DIAGRAM

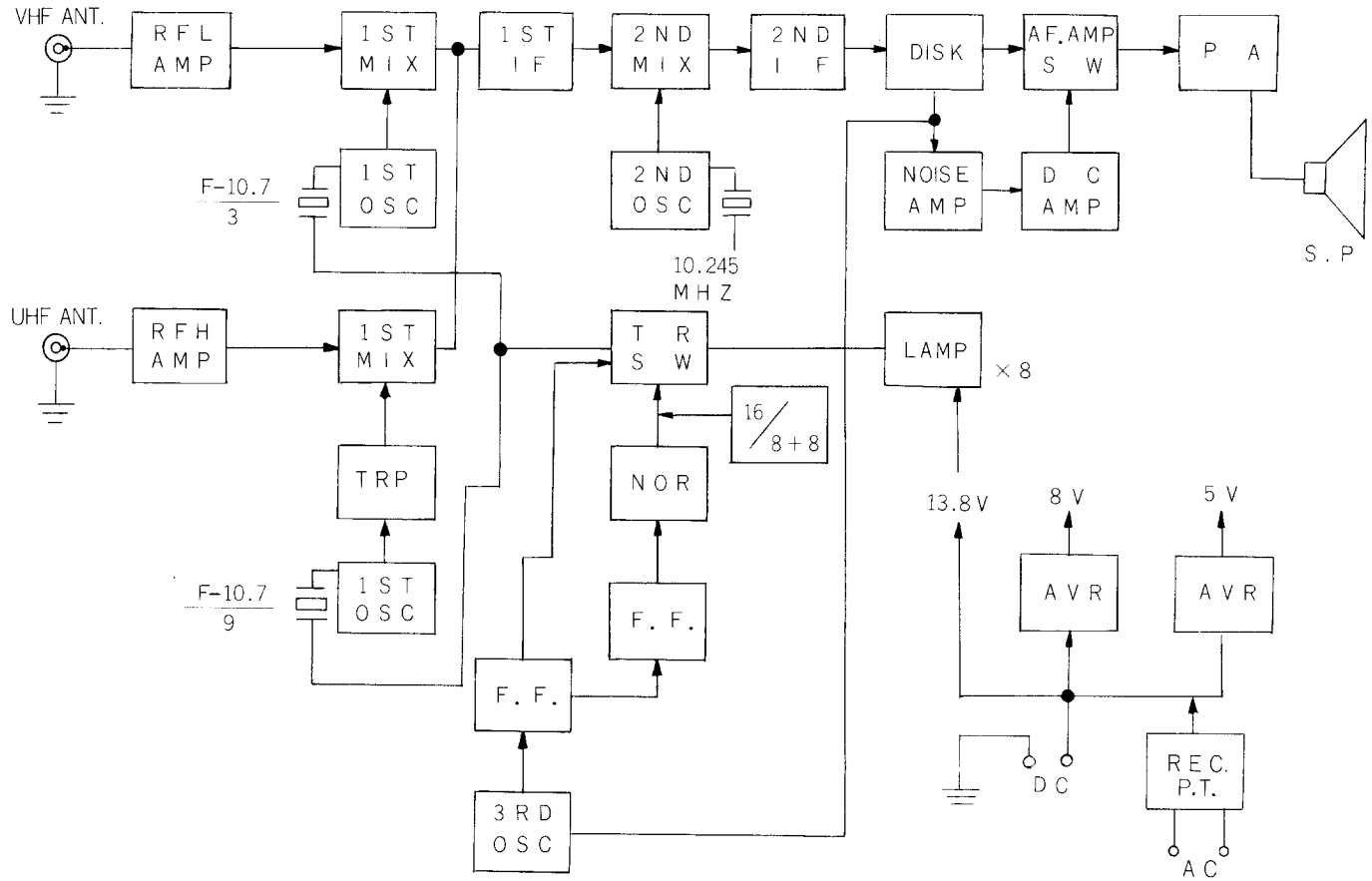

# SCHEMATIC DIAGRAM

